

oblustar®

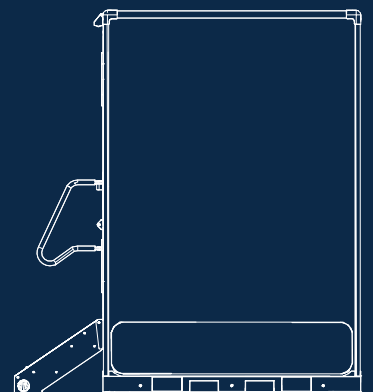

Brochure 2025

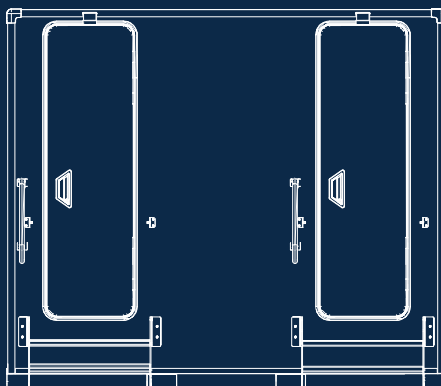
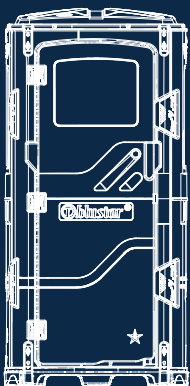
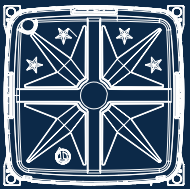
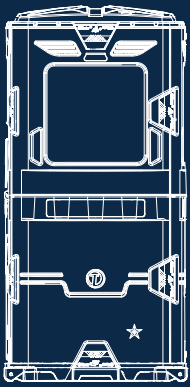

NOW,
THE FUTURE





Setting the benchmark for quality and innovation in portable sanitation and mobile restroom equipment.

For over eight years, our group has been dedicated to the design and production of portable sanitary solutions tailored to meet the needs of portable toilet rental operators worldwide. Thanks to the consolidated experience of our CEO Alessio Dainelli, shaped between Italy and the United States, and enriched by the creative vision of architect and designer Alessio Ravaioli, we have developed products that are distinctive, elegant, and built to last. Offering innovative, customizable, and high quality solutions, every product developed by Tblustar represents an investment in efficiency and quality.

Tblustar® offers a complete range of solutions:

Portable toilets	2
Equipment for portable toilet service	19
Service vehicles	22
Accessories and deodorizers.	27

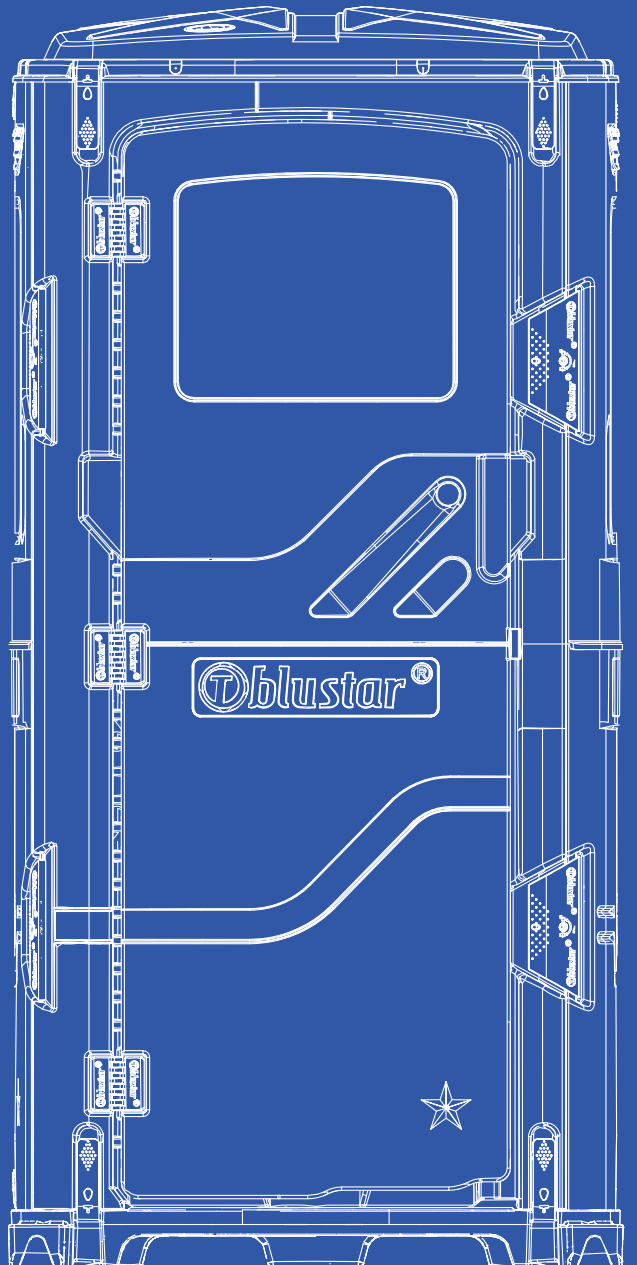
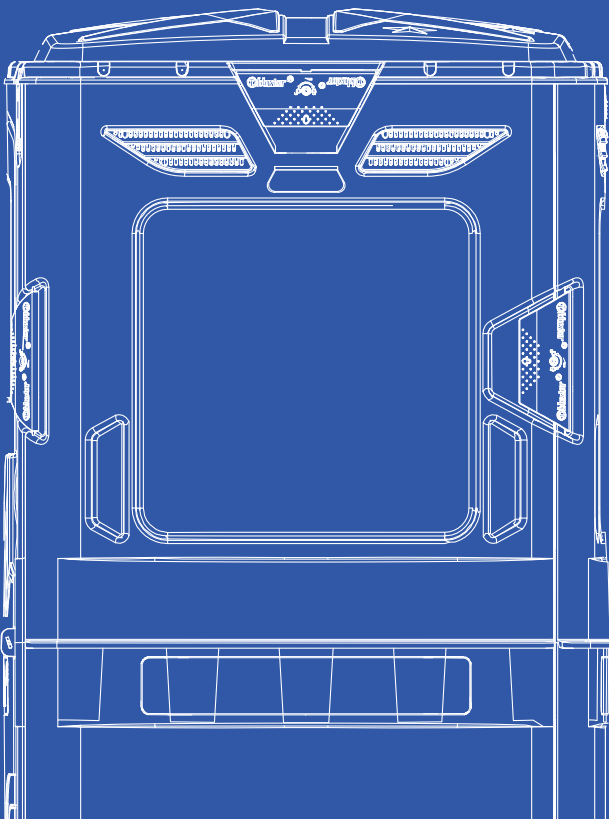
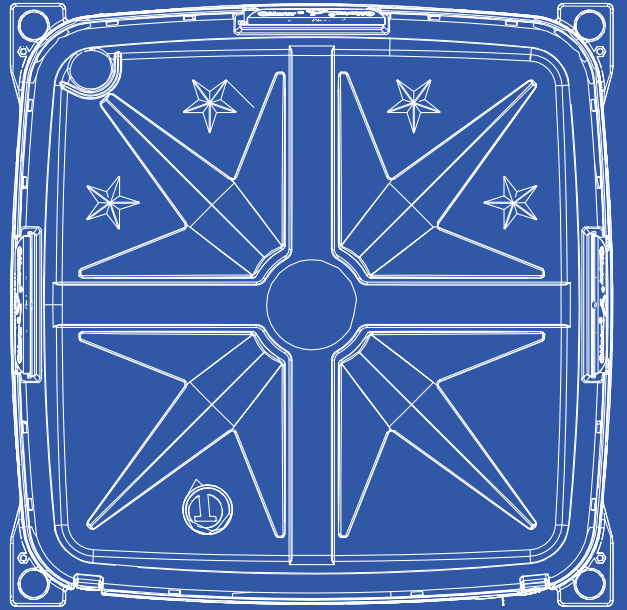

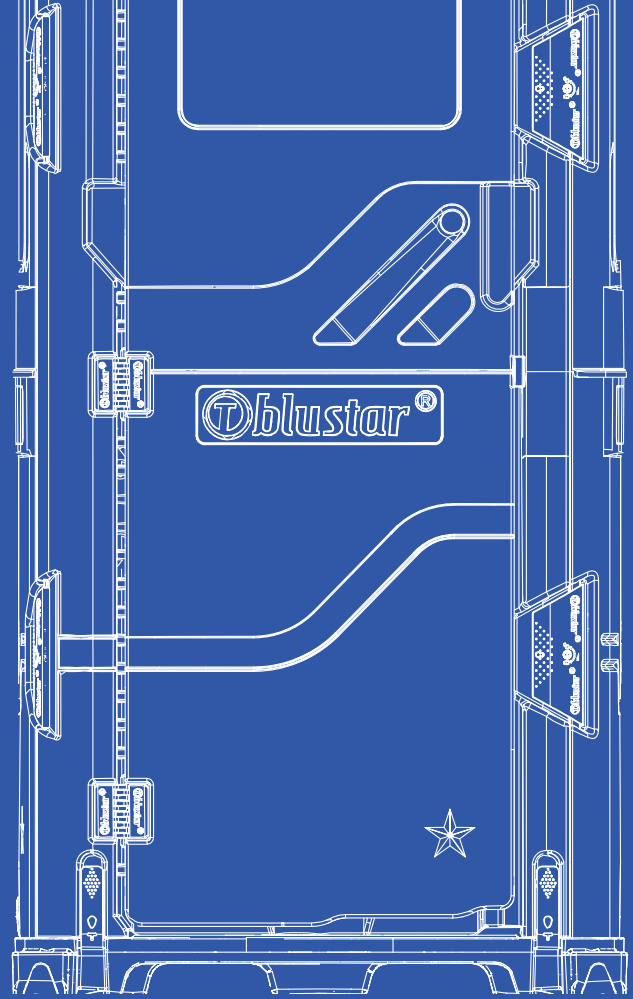
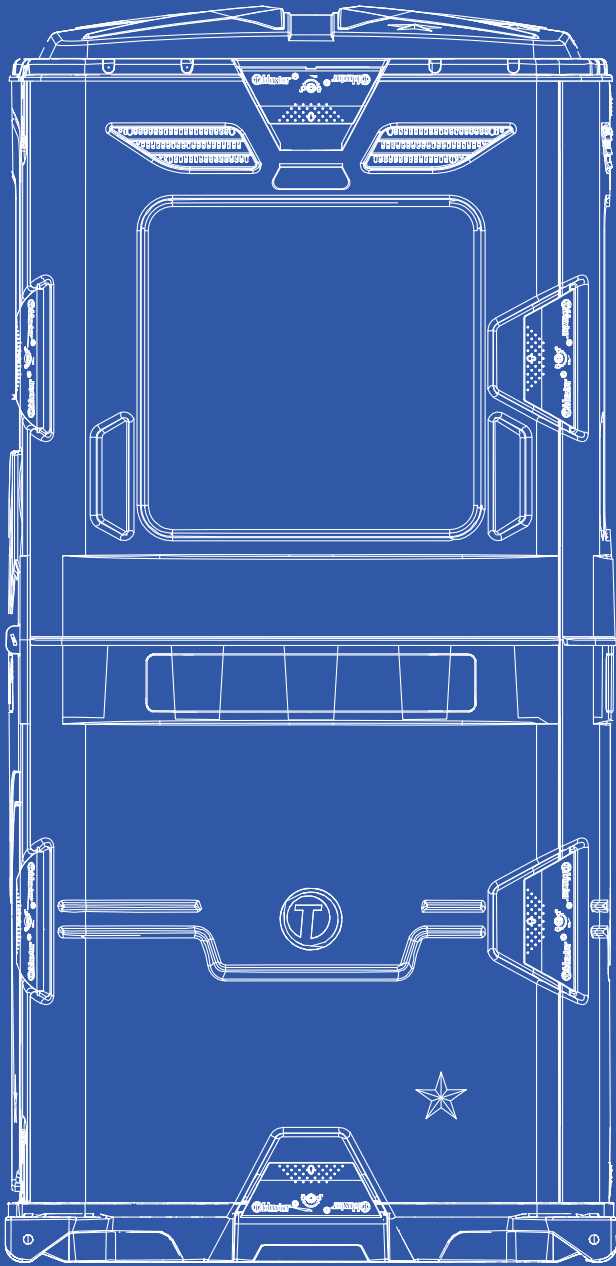

T STAR

T STAR

The patented chemical toilet for efficiency, design, and innovation



- 015
- R763
- v844
- RF1
- R04
- G11
- VC1
- 749
- V07
- O40
- B04



The **T-STAR** by Tblustar® is a **revolutionary chemical toilet** designed to meet the needs of operators in largescale events, construction sites, professional rentals, and extraordinary situations such as disasters, emergencies, military exercises, and remote camps.

Quick assembly: **patented system** allows mounting/dismantling in under **3 minutes** without tools. This unique approach delivers outstanding benefits in terms of **cost savings, sustainability, and practicality**, positioning the **T-STAR** as the ideal choice for those seeking innovation, cost optimization, and reliability

Lightweight yet robust components: shockproof components ensure durability and high performance. Integrated accessories: coat hook, reinforced door with double springs, three hinges, toilet paper holder for 3 rolls with protective compartment, antitheft locking rod.

Quality details: soft-close seat, double ventilation grids on each wall, red/green door indicators (free/occupied).

Storage optimization: T-Star 4pack reduces warehouse space by 75%. Store four units in the space of one—cutting costs and further protecting components from UV damage.

Transport optimization: 96 T-STAR units can be shipped in packs of 4 on a standard truck vs. 24 traditional toilets, cutting transport costs by 75%.

FRESH FLUSH system with foot pump

Featuring an integrated sink that delivers clean water to the flushing pump for superior hygiene.

RECIRCULATION flush system with foot pump

Featuring a closing diaphragm and foot-operated pump for superior hygiene and cleanliness.

DROP Version

Featuring an open waste tank for simple, functional use.

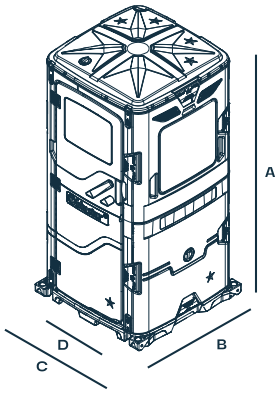

A 220 cm

B 109 cm

C 109 cm

D 62 cm

Weight 74 Kg

Floor area 0,56 m²

Holding tank capacity 180 l

SMART-PACKAGING

A 264 cm

B 109 cm

C 109 cm

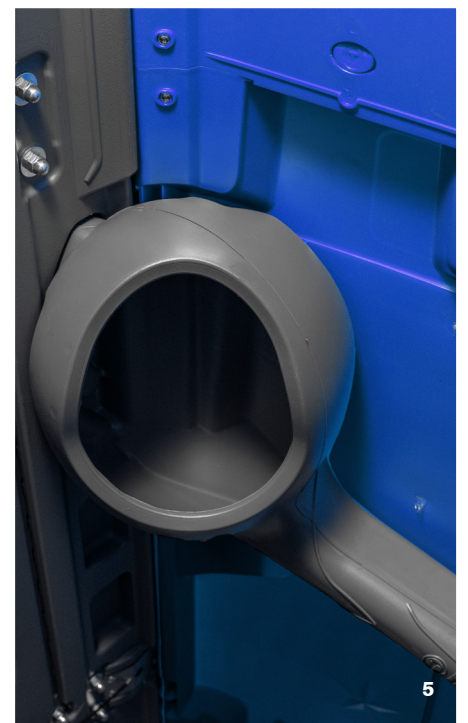
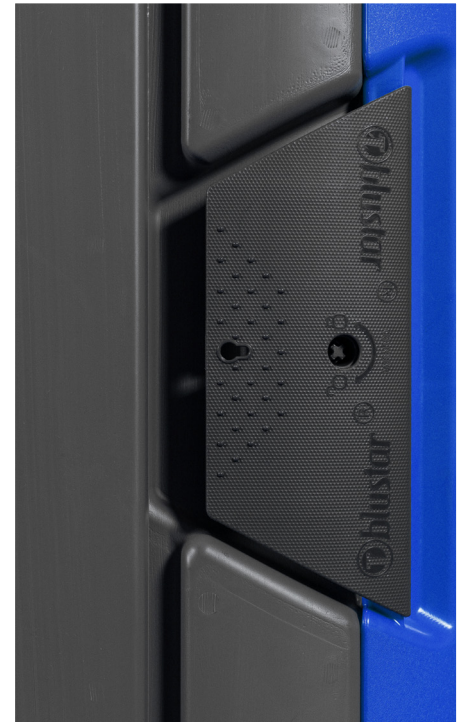

RP-Clean sink and Fresh-Flush configuration

A 115 cm

B 68 cm

C 25 cm

Weight 12 Kg

Water capacity 60 l



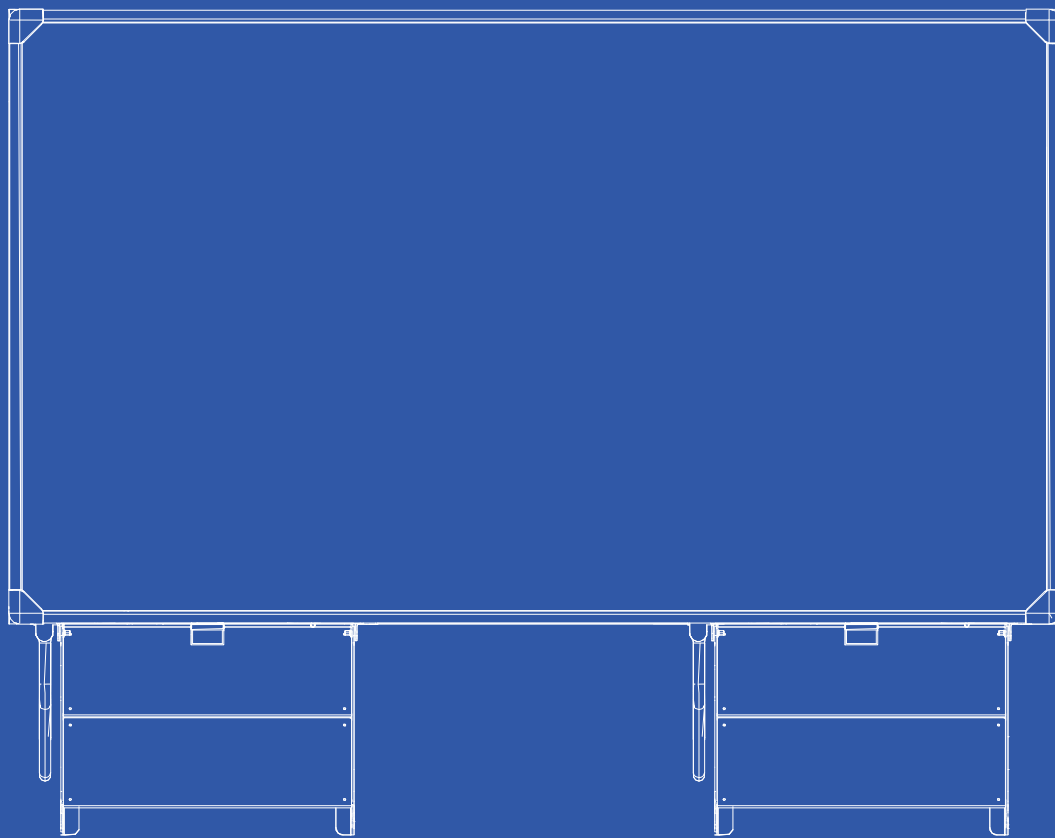
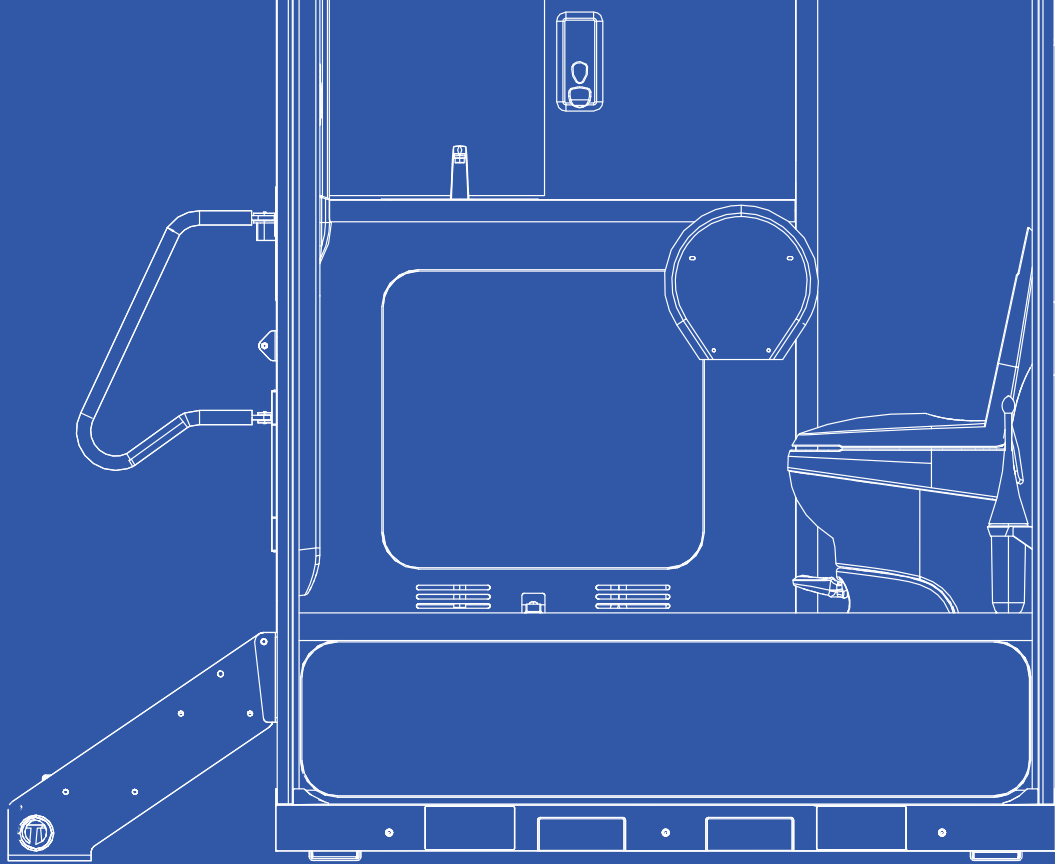

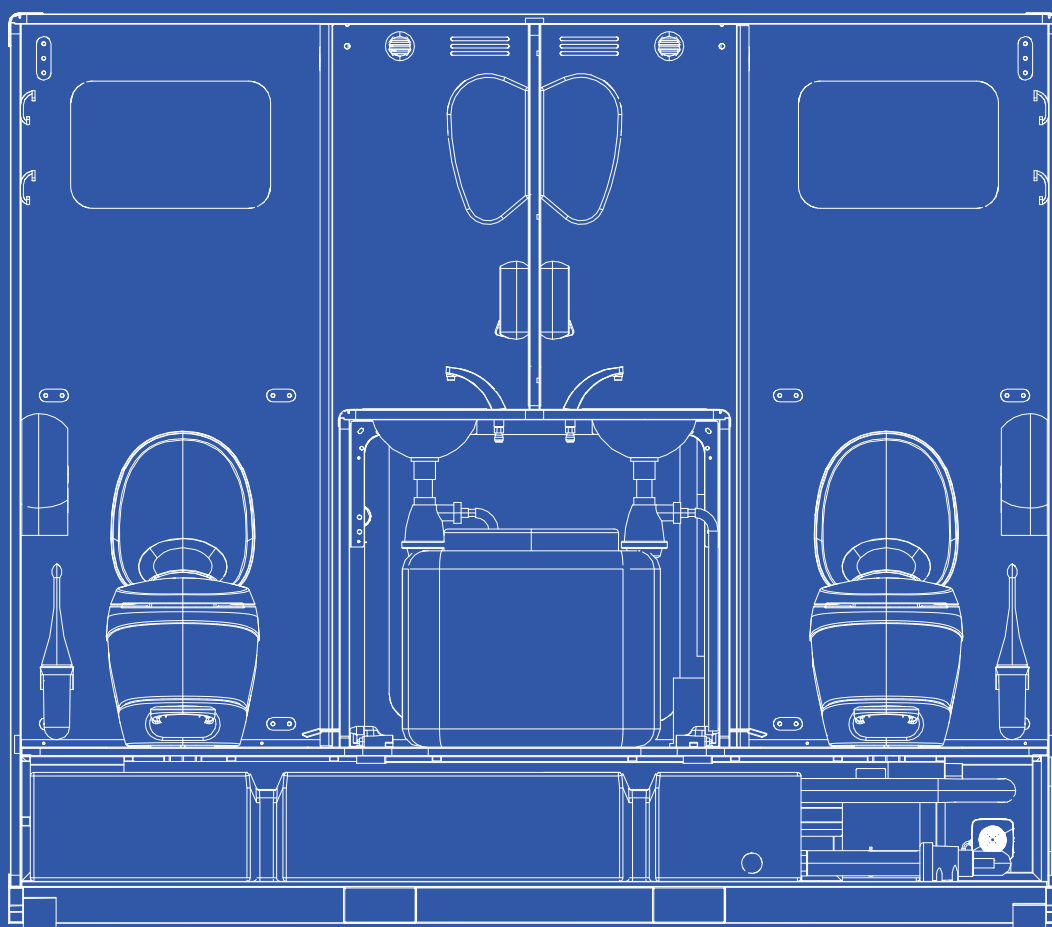

Twin

TWIN

The dual-station portable restroom for events and construction sites

Superior capacity

Two separate toilet stations for high user flow. T-WIN delivers privacy and seamless hygiene service with maximum efficiency.

Versatility

Usable on ground or trailer (B driving license). T-WIN is designed to fit effortlessly into any setting, from worksites to high-profile events.

Durability

Built with a steel platform and durable fiberglass panels, the T-WIN is a dual-station restroom designed to resist harsh conditions and deliver long-term performance.

- A** 254 cm
- B** 170 cm
- C** 290 cm
- D** 62 cm
- Weight** 800 Kg
- Water capacity** 500 l
- Wastewater and greywater capacity** 950 l

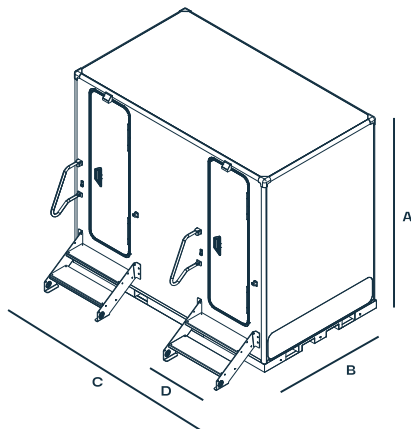

OPTIONAL

- Solar panels
- Heater
- Air conditioning
- Remote monitoring
- Electric hand dryer

The **T-WIN** is Tblustar®'s cutting-edge dual-station autonomous portable restroom, designed to deliver comfort and practicality in high-profile events, high-traffic venues, and construction sites.

With a robust structure and premium materials, **T-WIN** combines design,

efficiency, and functionality in a single product. **T-WIN** provides a complete solution to ensure top-level sanitary service in environments with a high number of users. Strong, versatile, and technologically advanced, **T-WIN** is the perfect partner for those seeking efficiency and quality.



2 access doors

2 locks with free/occupied indicator + master key

2 pedal-operated toilets

2 painted aluminum access stairs

1 technical compartment

2 LED lights with motion sensor

2 pedal-operated washbasins

2 mirrors

Air extraction system activated by presence sensors

Wastewater and greywater tank capacity 950 l

Clean water tank capacity 500 l

1 external LED light with motion sensor

1 external 220V power outlet

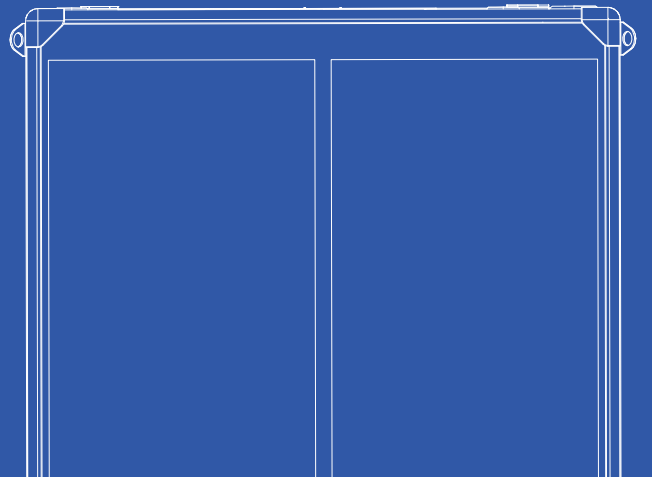
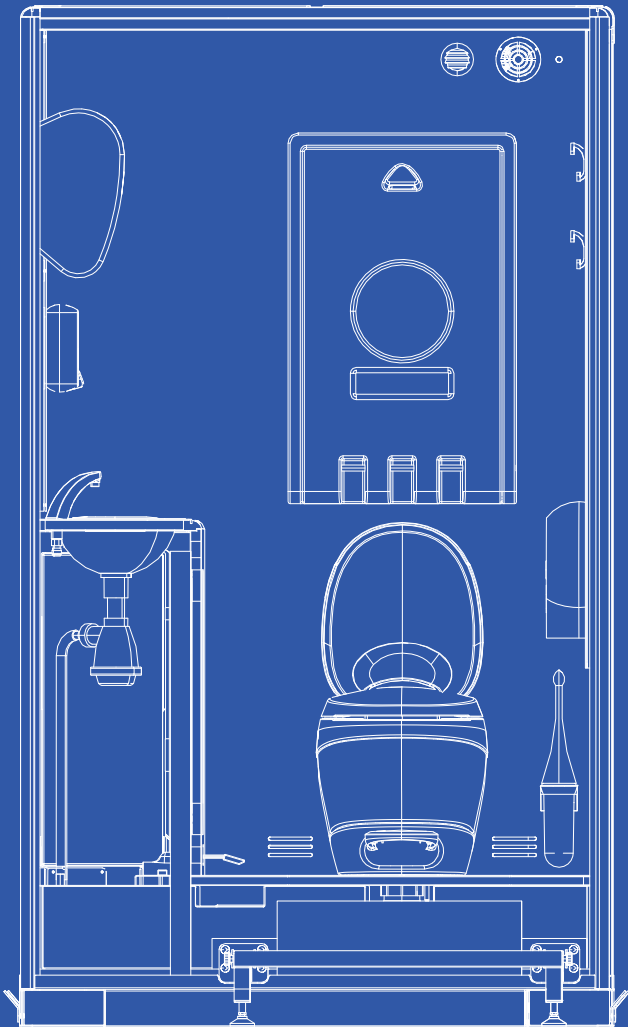

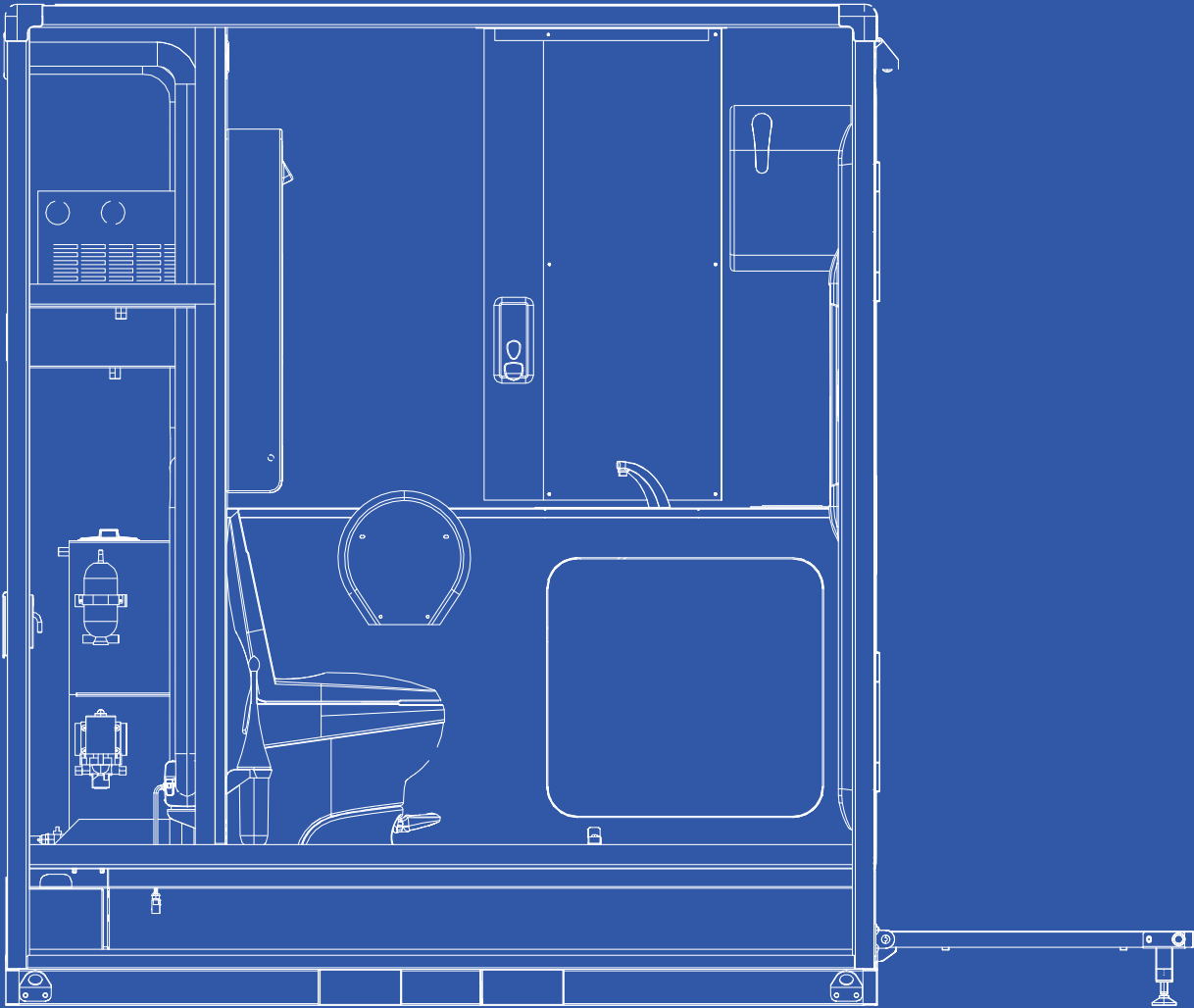
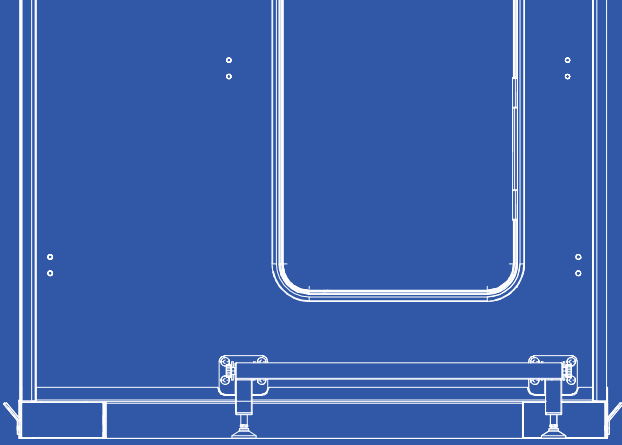

TWOW

T-WOW

The luxury portable toilet for prestigious events

Sustainable technology

With the option of next-generation solar panels, the T-WOW can operate autonomously 24/7, providing lighting and running water even without external power supply. Additional options include air conditioning, heating, and remote geolocation for tank management.

Elegant and functional design

T-WOW is designed for individual use, ensuring maximum privacy and comfort. The access door features a red LED indicator that shows whether the unit is free or occupied, along with an external unlocking system to guarantee safety.

Premium materials

Made with water- and wear-resistant materials, the T-WOW is built to last. Stainless steel tanks, a steel platform, and fiberglass panels ensure practicality and reliability even under intensive use.

A 254 cm

B 220 cm

C 150 cm

Weight 580 Kg

Water capacity 300 l

Wastewater and greywater capacity 650 l

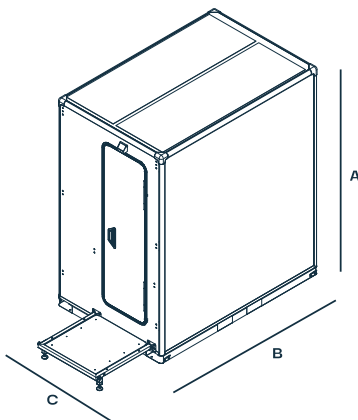

OPTIONAL

Solar panels

Heater

Air conditioning

Remote monitoring

Baby changing table

Electric hand dryer

The T-WOW by Tblustar® is synonymous with elegance, practicality, and reliability.

Designed to meet the needs of the most exclusive events, it is an investment that enhances every occasion, ensuring a sanitary service that lives up to the expectations of your guests.

The **T-WOW** is Tblustar®'s luxury single-station portable restroom, created to deliver superior

comfort, privacy, and functionality in prestigious settings such as high-profile events and ceremonies. With meticulous attention to detail, modern design, and advanced technology, the **T-WOW** is the ideal choice for those who want to guarantee an impeccable hygienic experience for their guests.

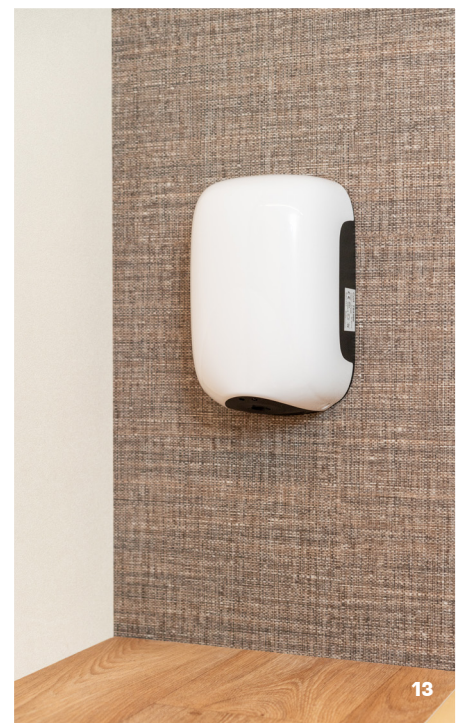
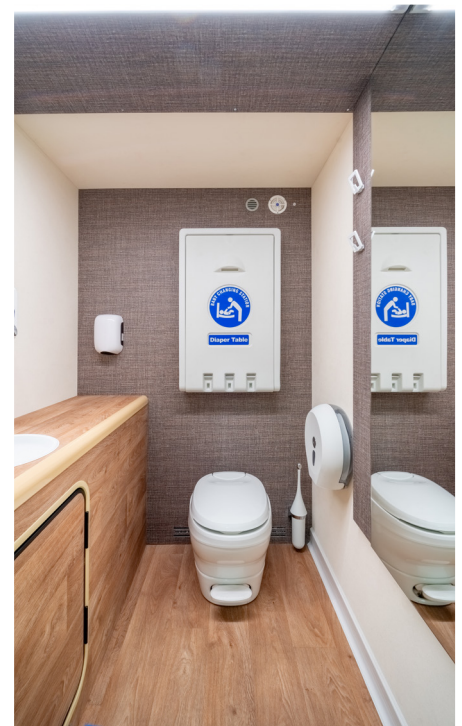

1 access door

1 lock with free/occupied indicator + master key

1 external support rail

1 painted aluminum access stair *

1 technical compartment

1 LED light with motion sensor

1 pedal-operated washbasin

2 mirrors

1 pedal-operated toilet

Air extraction system activated by presence sensors

Wastewater tank capacity 650 l

Clean water tank capacity 300 l

1 external LED light with motion sensor

1 external 220V power outlet

* Available in different heights for ground use or trailer installation

OTHER MODELS

myBlok



A 230 cm
B 106 cm
C 106 cm
D 62 cm
Weight 73 Kg
Capacità 230 L



T-Wash
 Sink for Myblock

Weight 7 Kg
Capacità 50 l



T-Flush
 Fresh water tank for
 MyBlok rinsing system

Weight 7 Kg
Capacità 60 l

Space FlatBase



The Space FlatBase portable restroom is designed to provide easy use for people with reduced mobility.

It is the ideal solution for events, parks, beaches, and recreational sites.

Its attractive design and dimensions comply with the European UNI-16194:2023 directive. The flat floor allows wheelchairs or strollers to enter easily and turn comfortably inside. Internal support rails help users stabilize themselves and move safely within the cabin.

A 215 cm

B 163 cm

C 163 cm

D 85 cm

Weight 175 Kg

Capacità 105 l

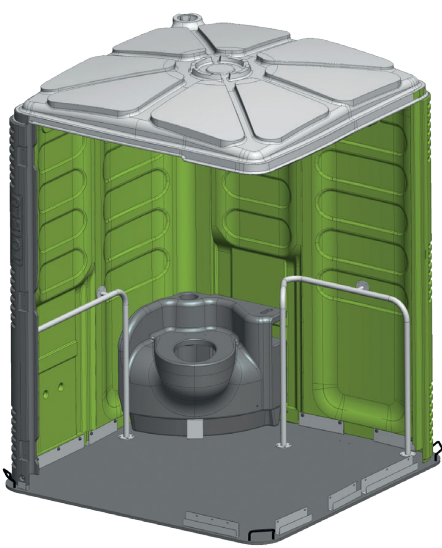

DROP TANK VERSION

With an open tank, simple and functional.

Available exclusively for Space FlatBase



FRESH FLUSH VERSION

Includes an integrated hand wash basin that supplies clean water to the pump for forced rinsing of the diaphragm for advanced cleaning.

Available for FlatBase and Spece160



Space160



- A** 215 cm
- B** 160 cm
- C** 160 cm
- D** 85 cm
- Weight** 165 Kg
- Capacity** 105 l

T-Round self cleaning



A 229 cm
B 115,5 cm
C 116 cm
D 216 cm
Weight 55 Kg
Capacity 205 l



T-P urinal
 External urinal option for
 T-Round
A 160,5 cm
B 54,6 cm
C 58,6 cm
Weight 12 Kg
Capacity 110 l



T-Roundwash
 Handwash for T-Round
A 172 cm
B 47 cm
C 32 cm
Weight 12 Kg
Capacity 40 l

TrioTank

The first service units in the world made entirely of polyethylene



SERVICE UNITS

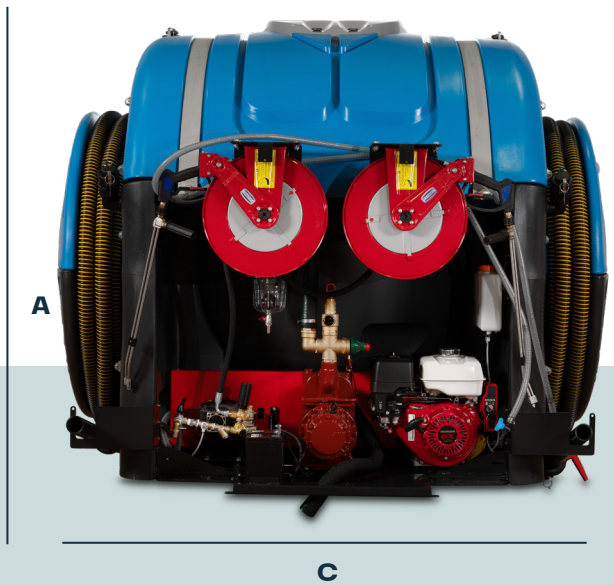

With this unit, operators can manage up to 35–40 chemical toilets per day, including washbasins. The TrioTank is composed of three independent 1000 l containers: 1000 l for wastewater suction, 1000 l for mixing water and detergent, used for cabin washing and restoring the 10–15 l inside each toilet tank, 1000 l of clean water for refilling cabin washbasins.

Each unit is equipped with auxiliary Honda GX270 engines featuring key ignition and an auxiliary battery for easy starting.

The Honda GX270 delivers enough power to drive a decompressor at 2600 l per minute, achieving a vacuum of -0.6 bar, and water pressure of 80 bar at 13 l per minute.

A 180 cm

B 185 cm

C 218 cm



ENGINE TYPES

MEC 2600

Jurop decompressor of 2600 L/min – Pressure pump 80 BAR 15 L/min
HONDA GX270 engine with auxiliary battery and key ignition

PTO 2600

Jurop decompressor of 2600 L/min – Pressure pump 80 BAR 15 L/min
– powered by hydraulic motor

Two series available

The **TrioTank Professional** mounts two side hoses for wastewater suction, each 15 meters long, and two hoses for washing of the same length.

Whereas the **TrioTank Superlight** mounts only one wastewater suction hose and one for pressure washing.

Both are equipped as standard with a 5-liter tank to mix, together with water, disinfectant products such as our BLU WATER chemical, or simply antifreeze to prevent ice formation during the cold months of the year.

TrioTank Superlight

Clean water capacity 1000 l

Wastewater capacity 950 l

Highpressure washing lance 1 x 15 m

Wastewater suction hose 15 m

Approximate weight 695 Kg

TrioTank Professional

Clean water capacity 1000 l / 2000 l

Wastewater capacity 950 l / 1950* l

Highpressure washing lance 2 x 15 m

Wastewater suction hose 15 m

Approximate weight 835 Kg

* with transfer valve

SST-304 Service unit

Maximum operational efficiency

All SST-304 models are in stainless steel, designed to last over time and guarantee reliability even in the most demanding conditions, and are equipped with:

- **High-pressure washing system**
- **Double 15 m hoses for suction and washing**
- **Powder-coated tank available in different colors**



Other colors available on request

COMPACT

The SST-304 Compact Service tank is designed to guarantee high performance and durability in a compact format. Made of stainless steel and powder-coated, it is ideal for suction operations in confined spaces or for those seeking a light but reliable solution.



ENGINE TYPES

Mechanical: Jurop decompressor of 2600 l/min – Pressure pump 80 BAR 15 l/min – HONDA GX270 engine with auxiliary battery and key ignition.

PTO: Jurop decompressor of 2600 l/min – Pressure pump 80 BAR 15 l/min – powered by hydraulic motor.

Electric: MEC 1000 decompressor of 1000 l/min and electric water pump of 30 l/min – 30 BAR, powered by lithium battery pack of 900 Amp. (autonomy > 3 hours).

Supplied with remote control for switching on and off the electric motors at a distance (max 30 m) and battery charger of 80 Amp/h. Maximum charging time 10 h. Available for Compact and Standard versions.

Wastewater capacity 850 l

Clean water capacity 400 l

High pressure washing lance 2 x 15m

Wastewater suction hose 2 x 15m

Rollbar for fastening with strap 1 front – 1 rear

Approximate weight 560 Kg

Dimensions L 170 cm P 162 cm A 157 cm

STANDARD

The SST-304 Standard Service tank is a versatile and powerful solution for suction operations, designed to guarantee excellent performance and greater capacity compared to the Compact version.

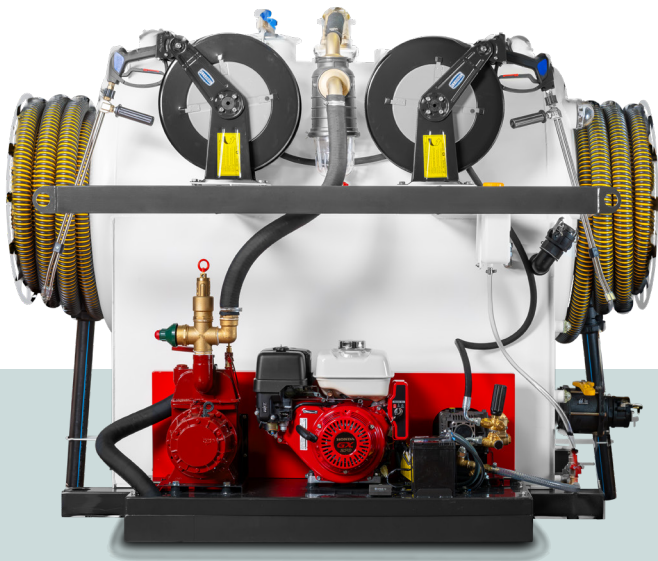

Wastewater capacity 1200 l

Clean water capacity 650 l

High pressure washing lance 2 x 15m

Wastewater suction hose 2 x 15m

Rollbar for fastening with strap 1 front – 1 rear

Approximate weight 780 Kg

Dimensions L 212 cm P 166 cm A 165 cm

MAXI

The SST-304 Maxi Service unit is the ultimate solution for intensive suction operations, designed to guarantee maximum capacity and superior performance in every operational context.



Wastewater capacity 2000 l

Clean water capacity 1000 l

High pressure washing lance 2 x 15m

Wastewater suction hose 2 x 15m

Rollbar for fastening with strap 1 front – 1 rear

Approximate weight 920 Kg

Dimensions L 229 cm P 188 cm A 165 cm

PIAGGIO Porter

NP6 Long Range

The **PORTER PIAGGIO NP6 Long Range** is the ideal solution for those operating in historic centres and confined spaces. Thanks to its compactness and remarkable load capacity, it is perfect for managing operations with efficiency and practicality. Equipped with **two 50-l tanks** (LPG and gasoline), it can host our **SST-304 Compact**, with a capacity of 850 l of wastewater and 400 l of water

Wheelbase 3250 mm

Fuel supply LONG RANGE GPL

1 Gasoline tank 45 l

1 LPG tank 55 l



COMPACT 1.4

Load capacity

1 T-STAR assembled or 1 SMART-PACKAGING T-STAR

1 service unit SST-304 Compact

COMPACT 2

Load capacity

2 disassembled T-STAR units

1 Service unit SST-304 Compact

2 Rp-Clean Star washbasins

2 urinals

FORD TRANSIT L3

The **FORD TRANSIT L3**, available in the 3.5 and 5.0 t, is the perfect vehicle for the management of chemical toilets in construction sites and work areas. With a power range **from 130 to 180 HP**, it can be equipped with our **SST-304 Compact units** (850 L of wastewater and 400 l of water) or **SST-304 Standard units** (1200 L of wastewater and 650 L of water).

Engine configuration and version TP CC Trd 165cv 350 L3

Fuel supply Diesel



TB-Ford-4.16

Load capacity

4 assembled T-STAR units or
4 SMARTPACKAGING T-STAR

1 Service unit SST-304



TB-Ford-4.10

Load capacity

2 SMARTPACKAGING T-STAR + 2
disassembled T-STAR units

1 Service unit SST-304 Compact/Standard

2 Rp-Clean Star washbasins

2 urinals

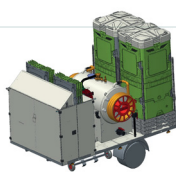

TB-Ford-4

Load capacity

4 disassembled T-STAR units

1 Service unit SST-304 Compact/Standard

4 Rp-Clean Star washbasins

4 urinals

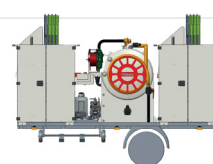

T·SEVEN

IVECO

The **T-SEVEN**, available in the 3.5 t version with single wheel, is ideal for the management of chemical toilets in construction sites and work areas. It has a power of 136 HP with mechanical transmission and an engine displacement of 2300 cc. It can be fitted with our SST-304 Compact or Standard service units.

Wheelbase 3450 mm

Engine configuration F1A 136CV EURO VIE HD

Fuel supply Diesel



T-SEVEN-4.16

Load capacity

4 assembled T-STAR units or
4 SMART-PACKAGING T-STAR

1 Service unit SST-304 Compact/Standard



T-SEVEN-4.10

Load capacity

2 SMART-PACKAGING T-STAR
+ 2 disassembled T-STAR units

1 Service unit SST-304 Compact/Standard

2 Rp-Clean washbasins

2 urinals



T-SEVEN-4

Load capacity

4 T-STAR disassembled

1 Service unit SST-304 Compact/Standard

4 Rp-Clean washbasins

4 urinals

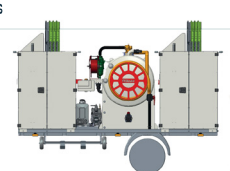

ISUZU

190 HP 7.5 Tons

With an impressive load capacity and a **190 HP** engine with a displacement of 5200 cc, the **ISUZU 190 HP 7.5 Tons** is designed for the management of large events and intensive operations. It is compatible with the **SST-304 Maxi**, which offers 2000 l of wastewater capacity and 1000 l of water.

Emissions EURO VI OBD-E

Displacement 5200 cm³

Power 190 HP

Fuel supply Diesel



Thanks to the possibility of transporting up to **16 T-STAR toilets** and towing the **T-JACK TRAILER** for a total of **28 T-STAR toilets**, the Isuzu guarantees unmatched efficiency.

In addition, it is equipped with an electrohydraulic platform with a load capacity of up to **800 kg**, to facilitate load and unload operations.

T·JACK TRAILER

With the **T·JACK TRAILER** it is possible to transport up to **3 SMART-PACKAGING T·STAR** units for a total of **12 T·STAR toilets**.





Chemical Product

BLUWATER

BLUWATER is the super-concentrated breaking-down product by Tblustar®, designed to guarantee maximum hygiene and the elimination of bad odors in wastewater tanks, even under extreme climatic conditions.

Adaptability

Ideal for large-scale use, with dilutions that offer an excellent quality/price ratio.

Operational sustainability

Available in different formats to meet every operational need.

Guaranteed effectiveness

Its concentrated formula neutralizes bad odors and keeps the water an intense blue color and pleasantly scented for a long time.

Features Mulberry fragrance for a more pleasant environment

Available formats 20 l, 210 l and 1000 l

Recommended dilution 1 liter for every 1000 l of water



1000 l



210 l



20 l



Portion control sachets

BLUPAC

BLUPAC is the single-dose capsule solution by Tblustar®, designed to guarantee practicality and high performance in containing odors coming from the wastewater collection tank, with high breaking-down power.

Operational savings

Compact and practical packages, ideal for transport and storage.

Ease of use

Each capsule is pre-dosed, ready to be used without waste.

Concentrated effectiveness

Guarantees excellent results for about 200 uses per capsule.



300 CAPSULES

longlasting deodorant discs

HALO

Formaldehyde-free deodorizing discs for the interior of cabins.

ELIMINATES TOUGH ODORS

Portable air freshener
24/7 fragrance protection
Use anywhere up to 30 days



HALO

CONCENTRATED AIR FRESHNER DISC



HALO

CONCENTRATED AIR FRESHNER DISC

Chemical Product

T-SCREEN

Formaldehyde-free concentrated solid deodorant for urinals with anti-clogging design.

CONCENTRATED AIR FRESHENER URINAL SCREEN

T-Screen is the perfect fragrance enhancer for your urinal. Our strong fragrances are designed to provide long lasting freshness for up to 30 days. Simply place one T-Screen in the urinal.

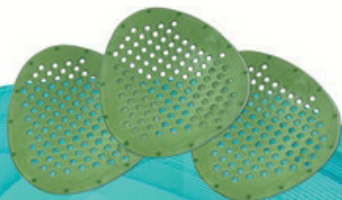

T-SCREEN

CONCENTRATED AIR FRESHENER URINAL SCREEN

T-SCREEN

CONCENTRATED AIR FRESHENER URINAL SCREEN

T.PAPER



Plies 2	Paper type Pura cellulosa
Sheets per roll 165	Grammage 15.5 g/m ²
Sheet height 9,5 cm	Color White
Sheet length 11cm	Embossing Micro
Roll length 18,15 m	
Roll diameter 10 cm	
Core diameter 4,5 cm	



**NOW,
THE FUTURE**

Tblustar S.r.l

Via Trentino Alto Adige, 10-12 - Poggibonsi (SI) 53036 Italy
+39 0577 1793364 +39 3761561235
info@tblustar.com
P.iva 06548510483

Tblustar USA

8520 Allison Pointe Blvd, Ste. 223 - Indianapolis, IN. 46250 USA
+1 (463) 237 1195
info@tblustar.com

Tblustar[®]